

4 - Prefab with Precast Brick Panels

4.1 - Introduction

The Detroit Integrated Transportation Campus (DITC) was to begin construction in October of 2008. However, due to complications with the General Contractor bid submissions, as of March, 2009 the project has yet to begin construction. Due to this delay, the State of Michigan will not only expect the construction to be completed within the expected one year construction period, but would find it beneficial to accelerate the construction and complete the job as soon as possible.

One of the current trends within the architecture and construction industry is leaning project delivery through the prefabrication of building systems. Prefabrication involves fabricating a system off site, bringing it to site in pieces, and installing those pieces on site. This process ensures quality because the systems are fabricated in shops; it also saves cost of on-site construction, and increases the rate of construction. The design of the Detroit Integrated Transportation Campus currently has typical brick on metal studs, which makes up one-third of the building's façade, with the rest of the building comprised of metal panels and strips of curtain wall windows. The brick on metal stud is currently on the critical path, and if the construction of this activity is expedited, the overall project schedule can be reduced.

Precast brick panels are fabricated in shops, and shipped to site to be erected, quicker than typical brick on metal stud is constructed on site. Because they are fabricated indoors, the quality and durability of precast brick panels is very high. Not only do precast brick panels increase the speed of construction when compared to typical brick, but they reduce the site congestion that is associated with typical masonry construction. Also, insulated precast panels can offer high R-Values, decreasing the heating and cooling loads of a building.

National Precast, Inc., located near Detroit, MI, is a company which manufactures many types of precast concrete products, including precast brick panels. The THERMOMASS insulated precast panel system, manufactured by National Precast, was selected to replace the typical brick on metal stud on the DITC for this analysis. National Precast was selected because of its close vicinity to the DITC, and their experience with construction in Detroit. In order to fully evaluate the substitution of National Precast's precast brick panel system its application to the DITC, structural impacts, mechanical impacts, cost and schedule impacts will have to be analyzed.

4.2 - Methods

1. Research the design of the precast brick panel system.
2. Analyze the application of National Precast's precast panels to the DITC.
3. Perform a structural breadth analysis of the new precast panel system.
4. Perform a mechanical breadth analysis of the new precast system.
5. Compare the cost of precast brick panels versus typical brick on metal stud.
6. Determine the schedule impacts of the precast panels on the DITC.

4.3 - References

1. Detroit Integrated Transportation Campus, 100% Construction Documents
2. National Precast, Inc.
3. ACI Concrete Design Handbook (SP-17) 1997
4. PCI Design Handbook: Precast and Prestressed Concrete 6th Edition, 2004
5. THERMOMASS Building Insulation Systems
6. Engineering Weather Data, Mcgraw Hill
7. 2005 ASHRAE Handbook - Fundamentals
8. R.S. Means Assemblies Cost Data, 2009 Edition

4.4 - System Overview

Precast brick panels selected for the DITC are insulated precast panels, and are comprised of three layers. The exterior layer has standard size half brick, 2 ¼ inches thick, with a mortar in between and behind the brick, giving this layer a total thickness of 3 inches. The next layer is the “sandwich” insulation, which is 2 inches of blue DOW insulation. The final, interior layer is a structural concrete mix that is 5” thick. This panel composition is referred to as a 3”-2”-5” configuration, and is held together using THERMOMASS connectors. THERMOMASS connectors, are high-strength, fiber-composite connectors that penetrate the insulation layer on both sides, allowing the concrete of both faces to form to the connectors. The connectors are not only high-strength, but because they are fiber-composite, they reduce the thermal bridging that is typically associated with metal connectors. A picture of the system can be seen below in Image 4.1.

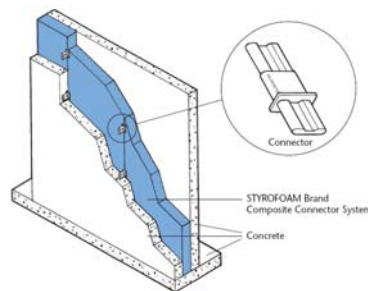

Image 4.1, THERMOMASS Precast Panel, The DOW Chemical Company

The precast brick panels are constructed in National Precast’s fabrication shop, and shipped to site to be erected. In the shop, the forms are laid out so that the exterior face is down. An image of a precast shop with forms laid out for pouring can be seen below in Image 4.2. The half brick with dovetails are set in place first, and the mortar layer is poured over top. Next, the panel, with the THERMOMASS connectors, is placed on top of the mortar layer. Last, the structural concrete is poured on top of the insulation. Once the panels have cured, and the formwork is removed they are ready to be shipped to site. The panels are shipped, and erected on site with a crane. Grab points for the crane are precast into the panels initially, and after they are used to set the pieces, they are removed.



Image 4.2, Precast Concrete Forms

There are many different possibilities when it comes to the layout and sizing of precast concrete panels. For transportation purposes it is important to limit either the height or the width of the panels to 8'-6". Therefore, the panels for the DITC could either be placed vertically, the whole height of the DITC with a width of 8'-6"; or horizontally spanning column to column, and stacked, each with a height of 8' - 6". For the DITC it was chosen to stack the panels horizontally, spanning from column to column. This layout required less connections, and therefore would cost less.

One option with precast panel walls is to make them structural, and allow them to carry the load of floors and roof located at the precast walls. National Precast found a similar job to the DITC, the Penta Career Center that they had constructed, and the precast wall system selected for the DITC was based off the precast system for the Penta Career Center. The system selected for the DITC will not carry the load of the floors and roof, which will remain supported by the exterior steel columns and beams in those areas. Even though this option is possible, a large amount of stress on the panels can cause the joint caulking to strip, and possible problems with the brick it-self. The precast wall panel system for the DITC will be stacked so that the bearing of the panels is transferred to the foundation below. The panels are laterally connected to the steel, but apply no vertical loading to the steel. This was important so that the size of the steel did not need to increase. All connections for the panels are inserts that are precast into the panels, connected to the steel on-site, and allow for movement because they are slotted connections. The panels are connected to each other at the vertical joints, at the bottom and top of each panel; and laterally connected back to the structural steel at these joints. The panels are stacked directly on-top of each other, and shimmed at each horizontal joint. The bottom of the panels rest directly on the foundations below, and are grouted to the foundation. The connections, illustrated below in images 4.3 – 4.6, were selected from the Penta Career Center, and will be the typical connections used on the DITC for the panels.

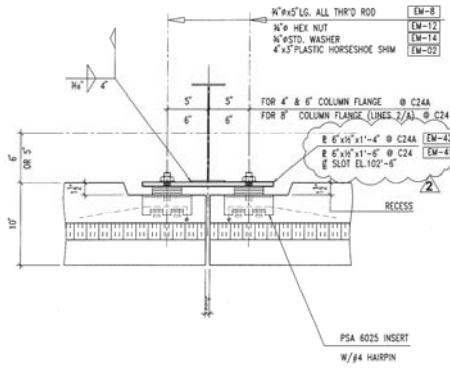

Image 4.3, Vertical Joint Connection at Column, National Precast

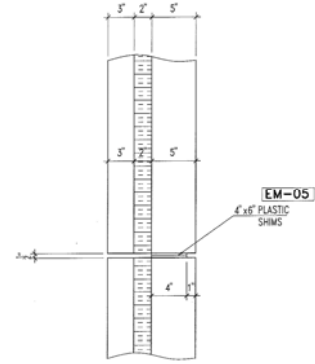

Image 4.4, Horizontal Joint Connection, National Precast

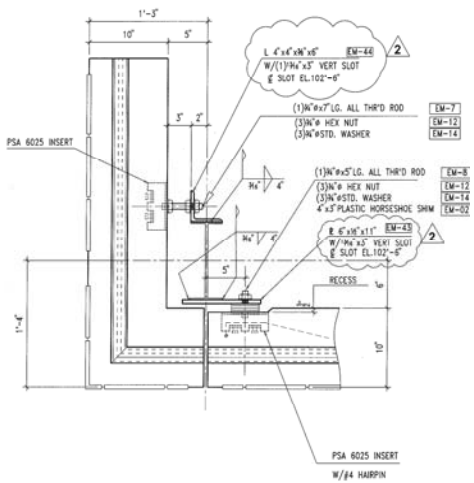

Image 4.5, Corner Joint Connection at Column, National Precast

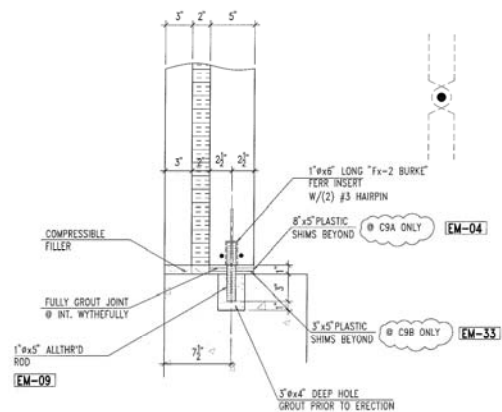

Image 4.6, Connection to Foundation at Panel Base, National Precast

The location of the brick exterior on the DITC is where the Michigan State Police control, dispatch, warrants, and server rooms are located. These interior spaces have an industrious feel with exposed ceilings, exposed structural steel, and a two-story control room. The space is currently designed with gypsum board on metal stud, to back up the exterior brick on metal stud. The precast brick panels have a finished concrete interior face, and therefore will not need gypsum board for the interior finish. The natural concrete feel will not only save money, without having gypsum board, but will add to the industrious feel of the spaces.

4.5 - Structural Impacts (Structural Breadth)

In order to assure the panel design and layout for the DITC would work, a structural analysis had to be performed. This analysis involves calculating the wind load and bearing load of the panels, and checking the panels for flexure and compression. Also, the current foundation wall supporting the original brick on metal stud had to be redesigned and checked for compression. All calculations for this structural analysis can be found in Appendix D.

Wind data for the DITC was gathered from the 100% CDs of the building. The CDs had the following data:

Basic Wind Speed (3-second gust):	90 mph
Wind Importance Factor:	1.15
Exposure Category:	B
Internal Pressure Coefficient:	+/- .18
Interior Zone Wind Pressure:	16 PSF
Exterior Zone & Corner Zone:	18 PSF

Wind pressure was calculated using a 90 mph wind speed, and it was found the P_{s30} for the interior zone was 8.5 PSF, and the P_{s30} for the exterior zone was 12.8. These numbers were well under the pressures on the CDs, therefore those numbers were used for the wind pressure.

The panels were then checked in the vertical direction for flexure and compression. In order to assure every panels design was satisfactory, a bottom corner panel, with the greatest wind load and bearing load, was checked. The panel was checked using the strip method, and a one foot vertical section of the wall was used. It was found that the $\Phi M_n = 2.14$ foot-kip and the $\Phi P_n = 173$ kips, with an $A_s = .20$ in (#4 bars every foot). After applying the wind and dead load on the panels, it was found that $M_u = .305$ foot-kip and $P_u = 2.56$ kips. An interaction curve was developed for the panel based on these figures, and is below in Figure 4.7. The graph did not have to be readjusted to represent an actual interaction curve because the design proved to be very conservative.

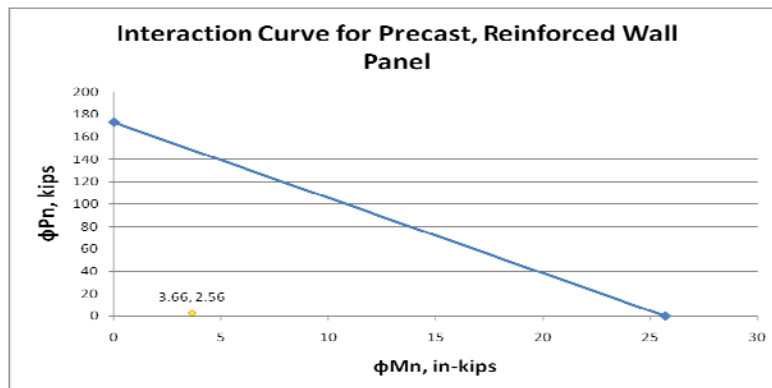

Figure 4.7, Interaction Curve for Precast, Reinforced Wall Panel

A second-order analysis of an un-braced member using the PCI Design Handbook was also used to check the design of the panels. This analysis proved to be valid with $M_u = .375$ foot-kips and $P_u = 2.05$ kips.

The panels were checked in the horizontal direction for flexure due to wind loading. This span is 22 feet, and the same $\Phi M_n = 2.14$ foot-kip could be used due to the same parameters of the vertical direction. The wind load was applied and it was found that $M_u = 1.05$ foot-kips, which was acceptable as it is less than ΦM_n .

Foundations had to be redesigned because there was no longer a need for a brick shelf. The size of the foundation could be reduced with the panel bearing directly on the footing. Checking for compression of the footing, V_u was calculated to be .853 kips, which was less than $1/2\phi V_c = 5.92$ kips; therefore, the design was acceptable. The new and original footing designs are below in Figures 4.8 and 4.9.

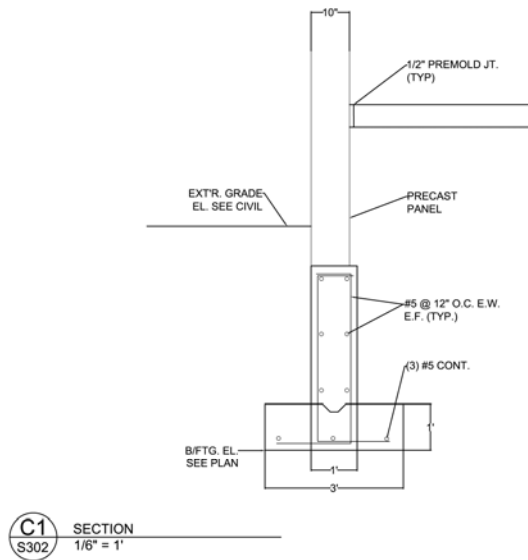

Figure 4.8, New Foundation Design for Precast Panels

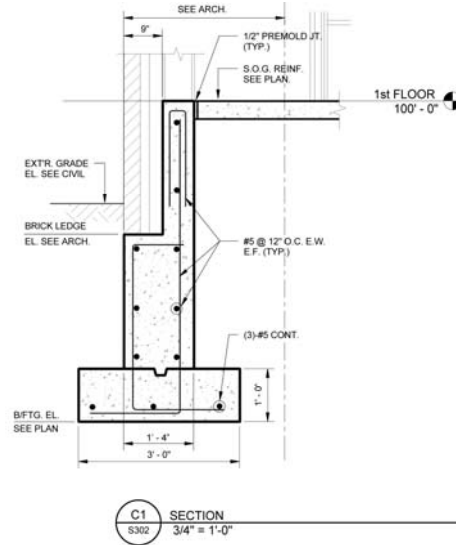

Figure 4.9, Original Foundation Design for Brick

4.6 - Mechanical Load Impacts (Mechanical Breadth)

The composition of the THERMOMASS precast panel system provides a good R-Value, which can reduce the heating and cooling loads of a building. The system offers a good R-Value because of the high R-Value of the 2" Insulation, the reduction of thermal bridging due to the fiber-composite connectors, and the increase in thermal mass due to the 5" layer structural concrete. Image 4.10 below is a thermal image of the THERMOMASS precast panel system, and it illustrates the constant R-Value of the panels as a product of the reduced thermal bridging.

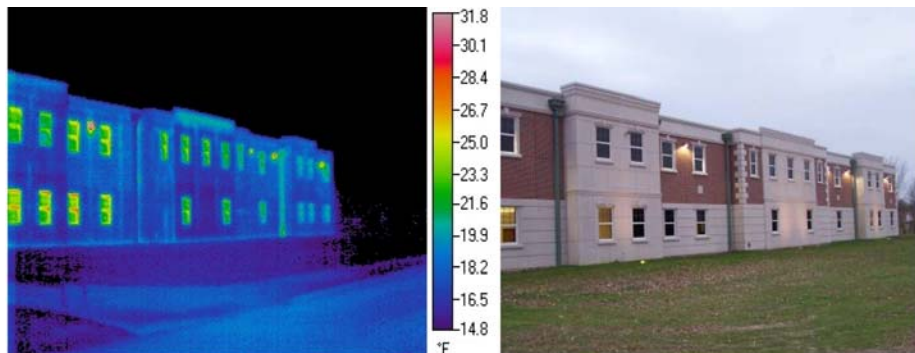

Image 4.10, Thermal Image, THERMOMASS Building Insulation Systems

In order to effectively compare the heating and cooling load difference between the typical brick on metal stud and the precast brick panels, the weather data for Detroit was obtained from the book “Engineering Weather Data”. The data below in Figures 4.11 and 4.12 represent the outdoor summer and winter temperatures, the indoor design temperature, and the heating and cooling degree days for the DITC.

Winter Temperature (Degrees Farenheit)	
To	5
Ti	68
ΔT	63
Heating Degree Days (HDD)	6478

Figure 4.11, Detroit Winter Data, Engineering Weather Data

Summer Temperature (Degrees Farenheit)	
To	84
Ti	68
ΔT	16
Cooling Degree Days	727

Figure 4.12, Detroit Summer Data, Engineering Weather Data

Also, to effectively compare any changes to the heating and cooling loads for the DITC, the heating and cooling capacity of the Rooftop AHU supplying the affected operations zone was gathered from the 100% Construction Documents for the DITC. These capacities are represented below in Figure 4.13.

Roof Top Unit Heating and Cooling Capacities					
Unit	Area Serviced	Heat - Loss (Heating)	Unit	Heat - Gain (Cooling)	Unit
RTU - 1b	Operations	216 MBH		20	Tons
		216000 BTU/hr		240000	BTU/hr

Figure 4.13, RTU Heating and Cooling Capacities, DITC 100% CDs

R-values for both wall systems had to be gathered in order to find the heating gains and losses of each assembly. A report generated by THERMOMASS compared the R-value’s of the THERMOMASS system to a typical panel assembly, including the loss due to thermal bridging. The assumed R-value in the study for a typical, non-THERMOMASS, panel assembly with 3” of insulation was similar to the brick, air cavity and insulation of a typical brick on metal stud façade of the DITC; therefore, the R-Value of this assembly was taken from the report including the loss due to thermal bridging. The effective R-Value of the brick on metal stud, air cavity and insulation was 10.81, reduced from 16.66 due to thermal bridging effects. The report used the Series-Parallel Path Analysis from the ASHRAE Handbook – 2001 Fundamentals, and it can be viewed in Appendix E. The precast brick panel system also benefits from the thermal mass of the concrete in the assembly. The system maximizes the thermal mass effect, thereby reducing heating and cooling loads, effectively providing an R-Value greater than expected. THERMOMASS performed an analysis to find the effective R-Value of the system, accounting for thermal mass, using ASHRAE/IESNA Standard 90.1: System Performance Criteria. This report is available in Appendix E, showed the R-Value of the system increased from 11.49 to 20.64 due to the effects of thermal mass. The remaining R-Values of the layers not included in these studies were found in the 2005 ASHRAE Handbook – Fundamentals. The R-Value of each assembly was calculated using all values, and each assembly’s R-Value calculation is shown below in Figures 4.14 and 4.15.

Brick Wall Composition		
Element	Thickness (in.)	R-Value
Exterior Surface Film	∞	0.167
4" x 12" Brick Veneer, Air Cavity, & 3" Rigid Insul.	8.625	10.81
Cont Vapor Retarder	-	0
1/2" Exterior Sheathing	0.5	0.625
Air Cavity & Studs + Gypsum Board	6.625	1.3
Interior Surface Film	∞	0.12
Total:		13.022
U-Value:		0.077

Figure 4.14, DITC Brick on Metal Stud R-Value Calculation

Precast Brick Wall Composition		
Element	Thickness (in.)	R-Value
Exterior Surface Film	∞	0.167
Precast Brick Wall w/ Thermomass Insulation Sys.	10	20.64
Interior Surface Film	∞	0.12
Total:		20.927
U-Value:		0.048

Figure 4.15, National Precast Brick Panel R-Value Calculation

After calculating the effective R-value of each assembly, the R-Values were applied to the DITC in order to calculate the Heat-loss in the winter and Heat-gain in the summer of each assembly. Because the precast panel system offers a higher R-Value, the heating and cooling loads for the DITC can be reduced. If large enough, the savings in heat-loss and heat-gain could reduce the size of the AHU supplying the operations zone of the DITC. The savings were compared to the existing AHU heating and cooling capacities in order to determine if they were large enough to reduce the size of the AHU. With the precast panel system the reduction of heat-loss was 4.5% of the heating capacity, and the reduction of heat-gain was 1.03% of the cooling capacity. These percentages were not large enough to decrease the size of the AHU supplying the operations zone. The calculations for heat-loss and heat-gain, and the comparison to the existing AHU capacities can be seen below in Figures 4.16 and 4.17. The heat-loss and heat-gain (Q) in BTU/hr was calculated using the equation: $Q = U\text{-value} * \text{Area} * \Delta T$.

Heat-loss (Winter)				
Assembly	U-Value	Area (SF)	ΔT (°F)	Heat_loss (BTU/hr)
Brick Assembly	0.077	5320	63	25737.98
Precast Panel Assembly	0.048	5320	63	16015.67
Difference:				9722.31
Existing AHU:				216000
% Difference:				4.50%

Figure 4.16, Heat-loss Calculation and AHU Heating Capacity Comparison

Heat-gain (Summer)				
Assembly	U-Value	Area (SF)	ΔT (°F)	Heat_gain (BTU/hr)
Brick Assembly	0.077	5320	16	6536.63
Precast Panel Assembly	0.048	5320	16	4067.47
Difference:				2469.16
Existing AHU:				240000
% Difference:				1.03%

Figure 4.17, Heat-gain Calculation and AHU Cooling Capacity Comparison

Even though the heat-gain and heat-loss savings from the precast brick panels were not enough to reduce the size of the AHU, these savings still contribute to savings in the operations costs of the building. Because the annual heating and cooling loads can be reduced with the precast panel system, savings occur with the energy costs required to heat and cool the building. The annual heating fuel consumption was calculated using the equation:

$$\text{Annual Heating Fuel Consumption} = [24 * Q * \text{HDD}] / [(T_i - T_o) * \text{HV} * \text{HEE}]$$

The equation was obtained from the book “Engineering Weather Data” and uses the heat-loss (Q), the heating degree days (HDD), the temperature difference ($T_i - T_o$), the heating value of natural gas (HV) and the heating efficiency of the AHU. The fuel consumption required for each wall system was calculated, along with the difference between the two fuel consumptions. The fuel consumption savings (difference between the annual heating fuel consumptions) was multiplied by DTE Energy’s (DITC energy supplier) cost for Natural gas to calculate the annual cost savings for heating load. The calculations for annual heating of the DITC can be seen below in figure 4.18. The total annual cost savings for heating of the DITC was \$350.43.

The annual cooling energy consumption was calculated using the same equation; however, it was changed to find cooling energy. The equation used was:

$$\text{Annual Cooling Energy Consumption} = [24 * Q * \text{CDD}] / [(T_o - T_i) * \text{CV}]$$

The equation uses the heat-gain (Q), the cooling degree days (CDD), the temperature difference ($T_o - T_i$) and the cooling value (CV) of the AHU. The cooling energy required for each wall system was calculated, along with the difference between the two cooling energies. The energy savings (difference between the annual energy consumptions) was multiplied by DTE Energy’s (DITC energy supplier) cost in \$/KWh to calculate the annual cost savings for cooling load. The calculations for annual cooling of the DITC can be seen below in figure 4.19. The total annual cost savings for cooling of the DITC was \$102.50.

Annual Heating Fuel Consumption = 24 (Q) (HDD) / (Ti - To) (HV) (HEE)		
Variable	Value	Unit
Brick on Metal Stud Wall System		
Q = Heat-loss for Brick Wall Systems	25738	Btu/hr
HDD = Total Annual Heating Degree Days	6478	"F * days
Ti = Indoor Design Temperature	68	"F
To = Outdoor Desing Temperature	5	"F
HV = Heating Value of Natural Gas	1027	Btu/ft ³
HEE = Heating Efficiency of Equipment	0.8	% / 100
Annual Heating Fuel Consumption	77308	Cubic Feet
Precast Panel Wall System		
Q = Heat-loss for Panel Wall Systems	16016	Btu/hr
HDD = Total Annual Heating Degree Days	6478	"F * days
Ti = Indoor Design Temperature	68	"F
To = Outdoor Desing Temperature	5	"F
HV = Heating Value of Natural Gas	1027	Btu/ft ³
HEE = Heating Efficiency of Equipment	0.8	% / 100
Annual Heating Fuel Consumption	48106	Cubic Feet
Difference		
Annual Heating Fuel Consumption Difference	29203	Cubic Feet
DTE Energy Natural Gas Cost	1.2	\$/Ccf
Annual Cost Savings	\$ 350.43	

Figure 4.18, Annual Heating Savings

Annual Cooling Energy (KWh) = 24 (Q) (CDD) / (To-Ti) (CV)		
Variable	Value	Unit
Brick on Metal Stud Wall System		
Q = Heat-gain for Brick Wall Systems	6536.63	Btu/hr
CDD = Total Annual Cooling Degree Days	727	"F * days
Ti = Indoor Design Temperature	68	"F
To = Outdoor Desing Temperature	84	"F
CV = Cooling Value (BTU/KWh)	3415	Btu/KWh
Annual Cooling Energy Consumption	2087	KWh
Precast Panel Wall System		
Q = Heat-gain for Brick Wall Systems	4067.47	Btu/hr
CDD = Total Annual Cooling Degree Days	727	"F * days
Ti = Indoor Design Temperature	68	"F
To = Outdoor Desing Temperature	84	"F
CV = Cooling Value (BTU/KWh)	3415	Btu/KWh
Annual Cooling Energy Consumption	1299	KWh
Difference		
Annual Cooling Energy Difference	788	KWh
DTE Energy Cost	0.13	\$/KWhr
Annual Cost Savings	\$ 102.50	

Figure 4.19, Annual Cooling Savings

4.7 - Cost Impacts

To obtain an accurate estimate of the precast brick panel system for the DITC, a takeoff of the panels was performed and sent to National Precast. The estimate received from National Precast used the number of panels, panel sizes and types of connection; and included fabrication, forms, detailing and engineering, field labor, transportation, erection, overhead and profit. The total price for the system received from National Precast was \$215,850 or \$42.93 / SF. To validate the estimate from National Precast R.S. Means Assemblies Cost Data, 2009 Edition was used to find the SF cost of a precast brick panel assembly. This assembly was not found in the book; therefore, the cost for an insulated precast panel was combined with the cost of masonry. This cost, available below in Figure 4.20, was much lower than the estimate received from National Precast; which is most likely due to the fact the combination of the precast panel and masonry did not accurately account for the design of National Precast's system.

Precast Brick Panel System - Cost Check	
System	Cost/SF
National Precast Brick Panel System Cost	\$ 43.34
RS Means Brick Panel System Cost	\$ 29.35

Figure 4.20, R.S. Means Precast Brick Panel Cost Check

The estimate received from National Precast did not include the Joint Caulking required between the panels. To account for this cost data was gathered from R.S. Means 2009, and the cost was added to the estimate for the precast brick panel system. The overall cost for the precast brick panels is represented below in Figure 4.21.

Cost of Precast Brick Panel Venerer		
Item	(+/-)	Cost/SF
Precast Brick Panel Venerer		\$ 42.93
Joint Caulking (R.S. Means 2009)	+	\$ 0.41
Precast Panel Cost/SF		\$ 43.34
Total SF of Precast Venerer:		5028
Total Cost of Precast Venerer:		\$ 217,913.52

Figure 4.21, Total Cost of Precast Brick Panels

In order to compare the cost for the precast panels to the brick on metal stud an estimate of the brick on metal stud was performed using R.S. Means Assemblies Cost Data, 2009 Edition. The assembly was adjusted in order to obtain an accurate cost for the brick on metal stud assembly of the DITC. The cost of the system was calculated to be \$38.45 / SF, with a total cost of \$ 193,335.59. The calculation of this estimate is below in Figure 4.20.

Cost of DITC Brick Venerer Assembly		
Item	(+/-)	Cost/SF
Standard Brick Venerer Assembly:		\$ 25.80
Subtract: Standard Brick	-	\$ 16.40
Add: Grey Face Brick	+	\$ 16.85
Add: Stacked Bond (1.1 * Brick Cost)	+	\$ 1.69
Subtract: Building Paper	-	\$ 0.18
Subtract: Glass Fiber insulation	-	\$ 1.00
Add: Cont Vapor Retarder	+	\$ 2.14
Add: 3" Rigid Insulation	+	\$ 2.22
Add: Drywall Backing	+	\$ 1.37
Add: Interior Paint	+	\$ 1.03
Subtotal:		\$ 33.52
Add: 5% non-brick waste (*1.05)	+	\$ 0.86
Add: Scaffold	+	\$ 2.25
Subtotal:		\$ 36.62
Add: Detroit Cost Index (*1.05)	+	\$ 1.83
DITC Brick Venerer Cost/SF:		\$ 38.45
Total SF of Brick Venerer:		5028
Total Cost of Brick Venerer:		\$ 193,335.59

Figure 4.20, DITC Brick on Metal Stud Cost, R.S. Means 2009

Savings were incurred for the precast brick panels with the redesign of the footing supporting the panels. Because the brick shelf could be eliminated, the concrete, rebar and formwork associated with the brick shelf could be eliminated. It was calculated that 50 Cubic Yards of concrete could be saved. A Cost per Cubic Yard was obtained from R.S. Means 2009, including the concrete, rebar and formwork. The estimated savings for the new foundation is below in Figure 4.21.

Concrete Footing Savings		
Item	Cubic Yards	Cost/CY
Concrete, Reinforced x Detroit City Cost Index (1.05)	50	\$ 266.00
Total Savings:		\$ 13,965.00

Figure 4.21, Concrete Footing Savings

Once the total cost for each system was calculated the costs were compared. The cost of the brick on metal stud system includes the cost savings for the foundation. It was found that the precast brick panels cost \$10,612.93 more than the original brick on metal stud system, 5% more than the cost of the brick on metal stud system. This cost comparison is available below in Figure 4.22.

Cost Comparison		
Existing Brick Façade System	\$	207,300.59
National Precast Brick Panels	\$	217,913.52
Additional Cost for Panels	\$	10,612.93
Percent Cost Increase		5%

Figure 4.22, Precast Brick Panel vs. Brick on Metal Stud Cost

Cost savings were also incurred for the operations of the DITC. The increased R-Value of the precast brick panels saved \$ 452.90 annually in heating and cooling costs. The Return on Investment for the extra cost for the precast panel system was calculated by dividing the extra \$10,612.93 upfront, by the annual energy savings of the precast panel system. Assuming that inflation stays constant with energy costs, the payback period for the precast brick panels was calculated to be 23 years and 5 months. There is a possibility that energy rates will actually increase at a greater rate than inflation, and in this case the payback period of the precast brick panels will be less than estimated.

4.8 - Schedule Impacts

Precast brick panels are fabricated in shops, and shipped to site to be erected, quicker than typical brick on metal stud is constructed on site. Although the on-site construction is expedited, a precast brick panel system requires more lead time than a typical brick on metal stud construction. Durations for the activities that precede the on-site erection of the panels for the DITC were received from National Precast, and are as follows:

Drafting and Engineering:	4 weeks
Fabrication:	4 weeks

Therefore, the overall lead time for the panels is eight weeks. The General Contractor of the DITC would have to be well aware of this lead time, and schedule these activities to occur before the erection of the

panels. The construction durations for the panels to be used on the DITC were also received from National Precast, and are as follows:

Erection: 1 week
 Clean-up and Detailing: 1 week

Because the precast panels will replace all the typical brick on metal stud for the DITC, the activity of constructing the masonry could be eliminated from the schedule. Also the precast panels do not require exterior metal studs as a back-up. Therefore the exterior framing activities where the brick was located can be reduced in duration. The durations for the exterior framing were reduced according to the amount of exterior framing that was eliminated in each sequence. Figure 4.16 below shows the duration decreases applied to the brick masonry and the exterior stud framing, and the new durations of those activities.

Current Schedule Durations with Duration Decrease			
Activity	Duration (days)	Duration Decrease (days)	New Duration (days)
Exterior Framing, Seq 10-12	5	1	4
Exterior Framing, Seq 13-15	5	2	3
Exterior Framing, Seq 16-17	6	3	3
Brick Masonry, Seq 10-12	4	4	0
Brick Masonry, Seq 13-15	10	10	0
Brick Masonry, Seq 16-17	16	16	0
Total:	46	36	10

Figure 4.16, Brick on Metal Stud Duration Decreases

The decrease in duration for the brick on metal stud activities was 36 days. After subtracting the week for erection of the precast panels, the overall schedule duration decrease for the precast concrete panels is 31 days.

The brick masonry activities were removed from the DITC schedule, the precast panel erection activity was added, and the durations of the exterior framing activities were decreased. The erection of the precast panels could begin after the installation of the west stairwell structure. After adjusting the schedule for the activity changes, the overall project schedule was only decreased by 3 days (based on a 5-day work week). This decrease was minimal compared to the duration decrease of 31 days due to the precast panels. Even though the brick on metal stud construction was on the critical path, the schedule only decreased by 3 days because the construction of the metal panels originally finished 3 days ahead of the brick on metal stud construction. Therefore, after the addition of the precast panels, the critical path was pushed to the metal panel construction. Interior construction activities can't begin until the building is enclosed, which was dependant on both the brick on metal stud construction and the metal panel construction. The updated schedule including the precast brick panels is available in Appendix F.

It is not only important to look at the critical path activities of a schedule for acceleration scenarios, but it is important to also look at the activities with little total float. Accelerating a critical path activity may not help decrease a schedule if successor activities are also dependant on another activity with little float. This was the case when substituting precast panels for the brick on metal stud for the DITC. However, typical brick on metal stud construction is very dependent on weather conditions, and

therefore prone to possible delays. Removing this activity from the DITC by using precast panels helps to reduce the possibility of delays due to unfavorable weather conditions.

4.9 - Conclusion

Due to delay of the construction of the DITC, the project's completion date is continuously being pushed back. In order to increase the speed of construction, and decrease the overall project schedule, the project participants should look into replacing the typical brick on metal stud façade of the DITC with precast brick panels. After a comprehensive analysis it was determined that National Precast's brick panel system would increase the project's cost by \$ 10,613, decrease the building's annual operation costs by \$ 453, and decrease the overall project schedule by 3 construction days.

The precast brick panels for the DITC would not be vertically supported by the structural steel of the DITC; however, the panels are stacked and the bearing of the panels is transferred to the foundation below. The panels are laterally supported by the structural steel, with slotted connections that allow for movement. It was determined through structural analysis that the design of the panels was conservative and adequate to resist self and wind loading. The size of the foundation wall at the precast panels could also be reduced because the brick shelf is no longer needed. The new foundations were analyzed and it was determined the design was adequate to support the loading of the precast panels.

Although the substitution of the precast brick panels, utilizing the THERMOMASS system, does not reduce the size of the AHU supplying the affected areas, it does decrease the annual heating and cooling loads. This decrease in heating and cooling load is credited to the high R-Value of the precast panel assembly. The R-Value of the assembly is barely affected by thermal bridging due to the fiber-composite connectors, and increased due to the thermal mass of the concrete in the assembly. The R-Value of the precast brick assembly was calculated to be 20.927, compared to the brick on metal stud assembly's R-Value of 13.022.

From a construction management viewpoint it is recommended that the DITC change the original design intent of the building, and substitute the precast brick panels for the brick on metal stud. The upfront cost increase of the precast panels could be returned in 23 years due to the annual heating and cooling cost savings. This payback period could be even shorter if energy costs increase at a greater rate of inflation. Even though the overall construction schedule is only decreased by 3 days, eliminating the brick on metal stud removes any delays that are possible with masonry construction. Eliminating the masonry construction also gives way to a less congested site, as the scaffolding required for masonry would congest the southwest corner of the building, which is already tight to the street.